



# WEB-DON INC.

1400 AMERON DR.  
CHARLOTTE, NC 28206  
PHONE 704/375-0250  
800-532-0434  
FAX 704/334-3342

4215 N. PATTERSON AVE.  
WINSTON-SALEM, NC 27115  
PHONE 336/767-8800  
800-642-0525  
FAX 336/767-9779

2111-A HARROD ST.  
RALEIGH, NC 27604  
PHONE 919/876-9191  
800-662-7028  
FAX 919/876-6713

2820 SHOP ROAD  
COLUMBIA, SC 29209  
PHONE 803/695-1456  
800-321-9650  
FAX 803/695-0103

3315 MERCHANT CT.  
WILMINGTON, NC 28405  
PHONE 910/794-6909  
800-662-7028  
FAX 910/796-3904

216 INDUSTRIAL PARK RD.  
PINEY FLATS, TN 37686  
PHONE 423/538-1199  
888-331-3936  
FAX 423/538-1188

DEALER NAME \_\_\_\_\_ DATE \_\_\_\_\_ YOUR CUSTOMER \_\_\_\_\_  
CITY \_\_\_\_\_ PO NO. \_\_\_\_\_  
PHONE \_\_\_\_\_ FAX \_\_\_\_\_ SALESMAN \_\_\_\_\_

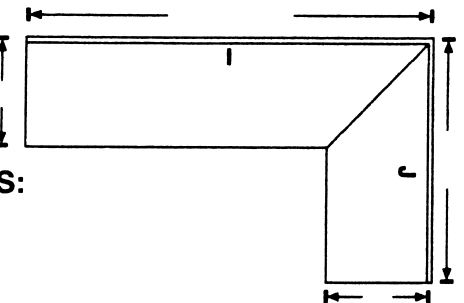
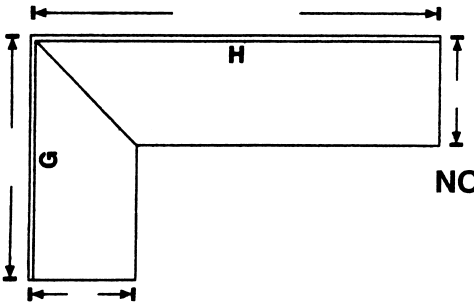
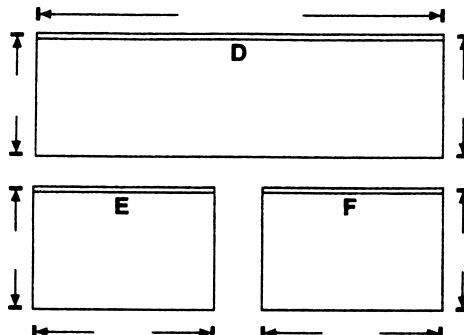
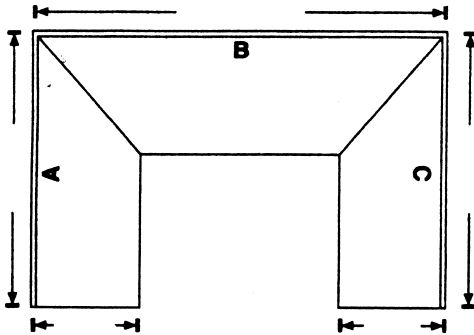

NOTES:

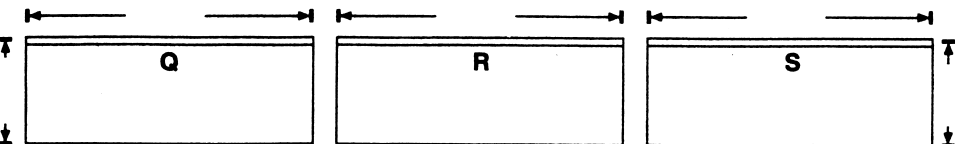
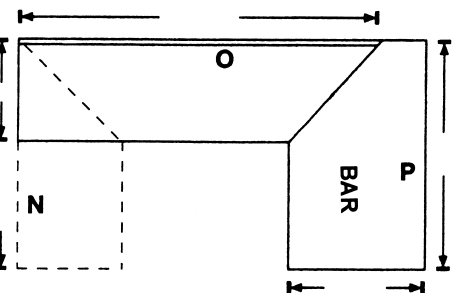
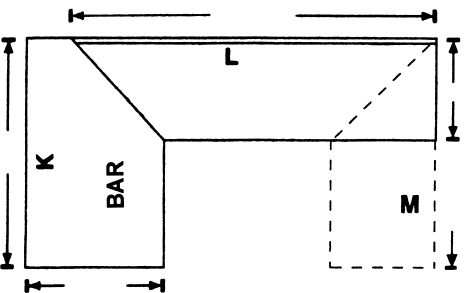

NO. DESCRIPTION

	TOP
	TOP
	TOP
	TOP
	TOP
	PERIMETER BUILD-UP
	END CAP ATTACHED
	END CAP LOOSE
	UNIV. END SPLASH LOOSE
	COPEDED END SPLASH LOOSE
	SCULPTURED SPLASH
	SINK CUT OUT
	BUTT JOINT
	MITRE
	RADIUS

- 1. ULTRA-TOP (WATERFALL)
  - 2. ULTRA-TOP (NO-DRIP)
  - 3. E-TOP 1200     4. E-TOP 1500
  - 5. EURO SQUARE (2000)
  - 6. DURA-TOP (SQUARE EDGE)
  - 7. COLONIAL WOOD (OAK EDGE)
  - 8. DIAMOND-TOP (BEVEL EDGE)
  - 9. AMORÉ     10. VIDA
- Specify Color Combination

C \_\_\_\_\_ B \_\_\_\_\_ E \_\_\_\_\_

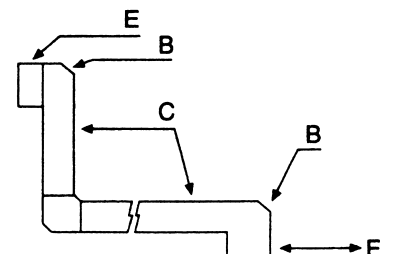

COLOR \_\_\_\_\_

APPROX. DELIVERY \_\_\_\_\_

STYLE \_\_\_\_\_

Via \_\_\_\_\_